

Planning & Field Guide for Pollution Prevention (P2)

Attachment to the P2 Plan for (insert address below):

4219/4221 Lorcom Lane, Arlington, VA 22207

Table of Contents

Introduction	1
Monitor the Weather	1
Good Housekeeping	1
Concrete Washout.....	2
Excavated Washout Structure.....	4
Washout Structure with Wood Planks.....	4
Washout Structure with Straw Bales	5
Prefabricated Containment System	7
Structure Construction, Stucco, Painting and Cleaning	9
Dewatering Operations	11
Filter Box.....	12
Straw Bale/Silt Fence Pit	13
Portable Sediment Tank	14
Filter Bag.....	15
Pump from Settling Pit	16
Manufactured System	16
Material Delivery and Storage.....	18
Chemical and Fuel Management and Storage.....	19
Solid Waste Disposal	22
Sanitary Waste.....	25
Equipment and Vehicle Maintenance	27

Introduction

This supplement highlights some of the common pollution-preventing practices that are used in Arlington. This supplement is intended to assist you with the creation of the required Stormwater Pollution Prevention Plan and provides suggestions of practices that help prevent pollution. Most pollution-releasing incidents from construction sites could have been avoided with the proper planning and implementation of best practices. Each practice should be appropriately sized for the specific project site where it will be implemented. Regular review, maintenance and adjustment, when necessary, of the practice is the responsibility of the construction site manager to ensure that only clean, clear stormwater leaves the site.

Some practices from Maryland's Department of the Environment are provided in this guide. These are acceptable examples that could be used in Arlington County. The drawings and their detail are available at:

http://mde.maryland.gov/programs/Water/StormwaterManagementProgram/SoilErosionandSedimentControl/Pages/2011_ESC_details.aspx

Monitor the Weather

It is extremely important to regularly monitor the weather forecast and plan accordingly when a construction site is active and/or unstabilized. It is the contractor's responsibility to:

- Schedule time to implement pre-storm plan when precipitation is predicted.
- Check containment practices after a precipitation event and maintain as necessary.

Good Housekeeping

Clean up sediment and debris along the curb and in the street every day using "dry" methods, such as shoveling, sweeping or vacuuming. The use of water to remove sediment and debris from the right-of-way will not be permitted under any circumstance. Remember - only clean, clear stormwater may leave a construction site.



Example cleanup methods. Left photo: vacuuming. Right photo: sweeping debris away from the storm drain.

Concrete Washout

Concrete wash water is directed into a leak-proof container or settling basin. The container or basin is adequately sized to ensure overflows do not occur, whether due to precipitation or inadequate sizing. Hardened concrete washes are removed and disposed of in a manner consistent with handling construction wastes. Grout and mortar work must also utilize a washout device.

Best Practices:

- ✓ Washouts must be sized appropriately for the needs of the site.
- ✓ Do not locate washouts near storm drains.
- ✓ Concrete washouts cannot be used for the purpose of dewatering. Concrete washouts and dewatering devices are not interchangeable.
- ✓ Don't mix more fresh concrete or cement than you will use in a two-hour period.
- ✓ Set up and operate small mixers on top of plywood that is covered by tarps or heavy plastic drop cloths, and bermed with stones around the edge.
- ✓ Set up mortar containers on top of a tarp or heavy plastic drop cloth.
- ✓ When cleaning up after driveway or sidewalk construction, use DRY methods such as sweeping, shoveling or use a street sweeper/vacuum truck.
- ✓ Wash down exposed aggregate concrete only when the wash water can drain onto a bermed surface from which it can be pumped and disposed of properly or be vacuumed from a catchment created by blocking a storm drain inlet. If necessary, divert runoff with temporary berms.
- ✓ Wash out concrete mixers in designated wash-out areas where the water flows into a temporary waste pit.
- ✓ Dispose of settled, hardened concrete as garbage.
- ✓ Ensure that tracking does not occur from the concrete washout area.
- ✓ Dewatering of accumulated stormwater can only be done through a chemical filtering sock.
- ✓ Concrete wash water and sawcut slurry are not allowed to enter a storm drain.



If debris is in the curb, a vacuum truck may be needed to clean up the area.

**Check which practice you will implement. Drawings and descriptions are in the following section.
If choosing “Other,” supply a drawing and detailed description (including maintenance) on page 8.**

___ Excavated Washout Structure

___ Washout Structure with Wood Planks

___ Washout Structure with Straw Bales

___ Prefabricated Containment System

- Name of manufacturer: _____
- Size: _____
- Attach the manufacturer’s specification sheet and detail of how it will be maintained.

___ Other

Approved Concrete Washout Practice Drawings & Descriptions

Excavated Washout Structure

The Maryland Standard H-6 for an onsite concrete washout structure is provided as an acceptable option for use in Arlington County.

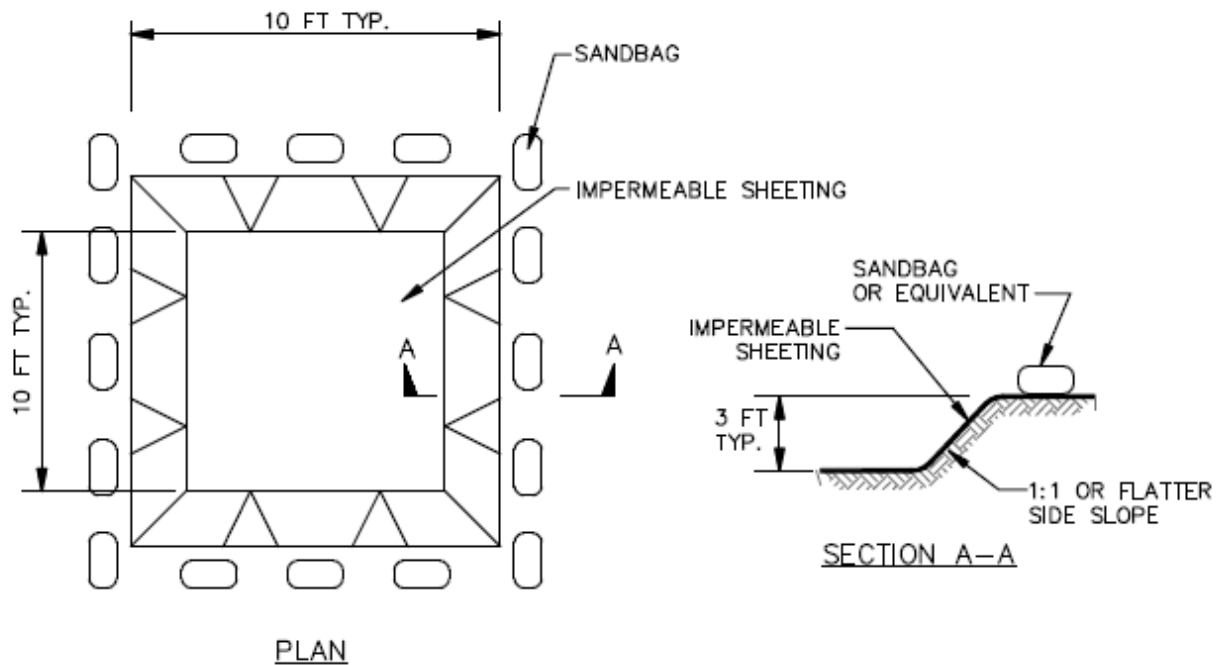

Washout Structure with Wood Planks

The Maryland Standard H-6 for an onsite concrete washout structure is provided as an acceptable option for use in Arlington County.

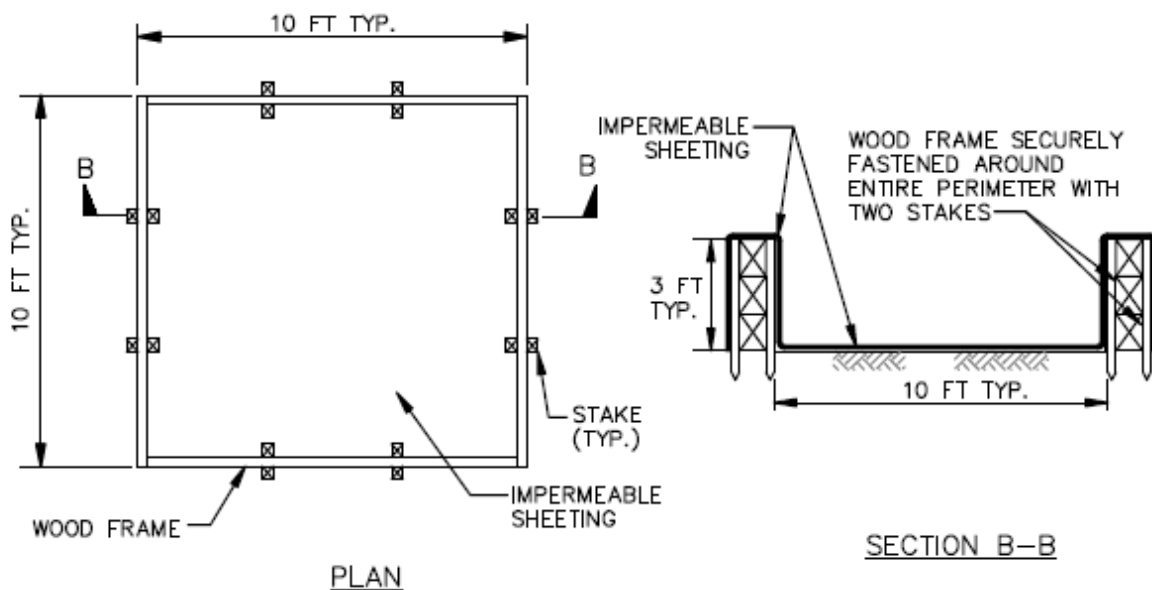

Washout Structure with Straw Bales

The Maryland Standard H-6 for an onsite concrete washout structure is provided as an acceptable option for use in Arlington County.

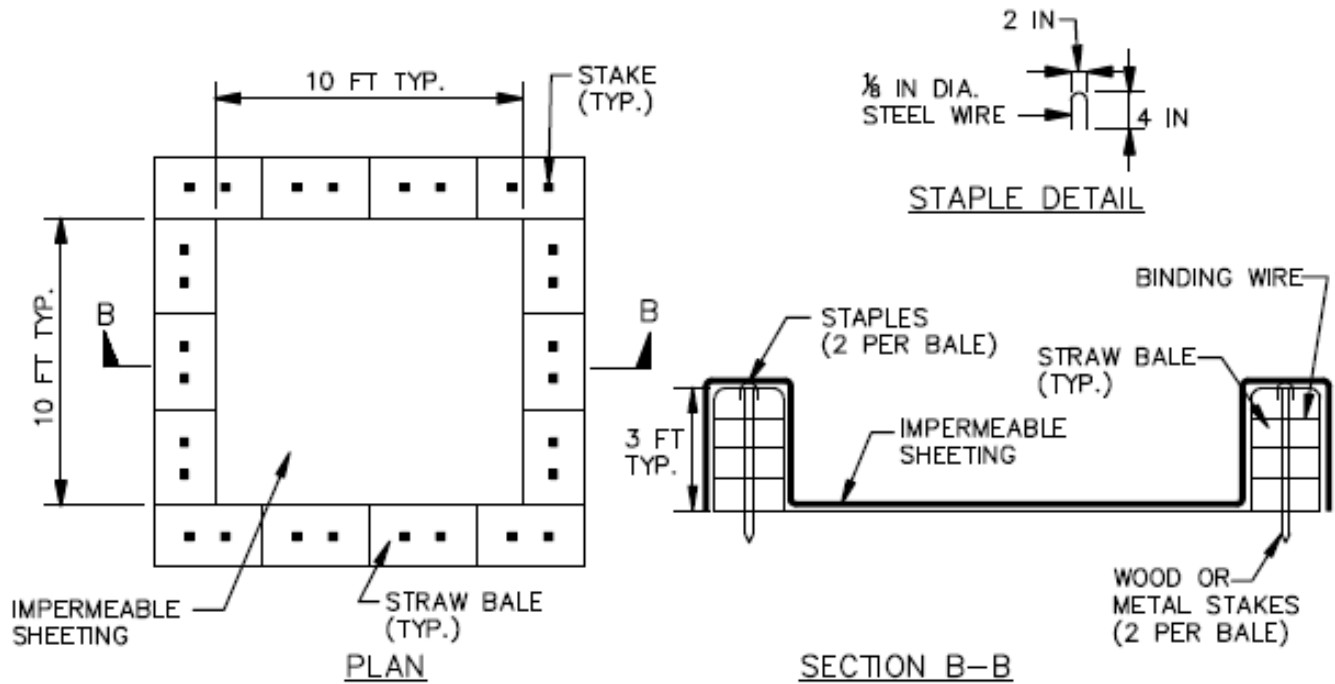

NOTE: CAN BE TWO STACKED BALES
OR PARTIALLY EXCAVATED TO
REACH 3 FT DEPTH



Example washout structures. Note that each example is fully lined and the washout is contained.

Prefabricated Containment System



Prefabricated containment example.

Concrete Washout Other

Supply a drawing and detailed description. Include information on practice maintenance.

Structure Construction, Stucco, Painting and Cleaning

Enclose, cover or berm building material storage areas if susceptible to contaminated stormwater runoff. Conduct painting operations consistent with local air quality and OSHA regulations. Mix paint indoors, in a containment area or a flat unpaved area. Prevent the discharge of soaps, solvents, detergents and wash water from construction materials, including the cleanup of stucco paint, form release oils and curing compounds.

Best Practices:

- ✓ Liquid waste may not enter a storm drain.
- ✓ Liquid wastes are to be contained in a controlled area, such as a portable tank.
- ✓ Containment must be structurally sound and leak-free.
- ✓ Containment must be sized appropriately for the needs of the site.
- ✓ Locate containment areas away from storm drains.

Examples for Structure Construction, Stucco, Painting and Cleaning Practices



Example paint washout structure.



Example small-scale concrete and paint washout area.

Structure Construction, Stucco, Painting and Cleaning Other

Supply a drawing and detailed description. Include information on practice maintenance.

Dewatering Operations

Construction site dewatering from building footings or other sources may not be discharged without treatment. Sediment laden or turbid water must be filtered, settled or similarly treated prior to discharge. The dewatering structure must be sized to allow pumped water to flow through the filtering device without overtopping the structure. Use a combination of filtering and inlet protection approaches described below to ensure that ONLY clear water leaves the site. Closely monitor and maintain the sediment removal devices to ensure they are not clogged and operate correctly. Make adjustments as site conditions change.

Check which filtering practice(s) you will implement. Drawings and descriptions are in the following section. If choosing “Other,” supply a drawing and detailed description that includes information on maintenance on page 17.

Filter Box

Straw Bale/Silt Fence Pit

Portable Sediment Tank

Filter Bag

Pump from Settling Pit

Manufactured System

- Name of manufacturer: _____
- Size: _____
- Attach the manufacturer’s specification sheet and detail of how it will be maintained.

Other

Check which inlet protection practice(s) you will couple with the filtering practice. See Arlington’s *Erosion and Sediment Control Supplement* and/or the Virginia Department of Environmental Quality’s *Virginia Erosion and Sediment Control Handbook* for inlet protection practice specifications.

If choosing “Other,” supply a drawing and detailed description that includes information on maintenance on page 8 of the E&S Supplement.

Filter Fabric Inlet Protection

Gravel Curb Inlet Sediment Filter

Block and Gravel Curb Inlet Sediment Filter

Block and Gravel Drop Inlet Sediment Filter

Silt Fence Drop Inlet Protection

Median Inlet Protection

Other

Approved Dewatering Practice Drawings & Descriptions

Filter Box

See the Virginia Department of Environmental Quality's *Virginia Erosion and Sediment Control Handbook*, Chapter 3-3.26 for additional design specifications. The box must be cleaned out once one-third of the capacity if filled with sediment. If the stones become clogged and the box stops properly functioning, the stones must be removed, cleaned and replaced.

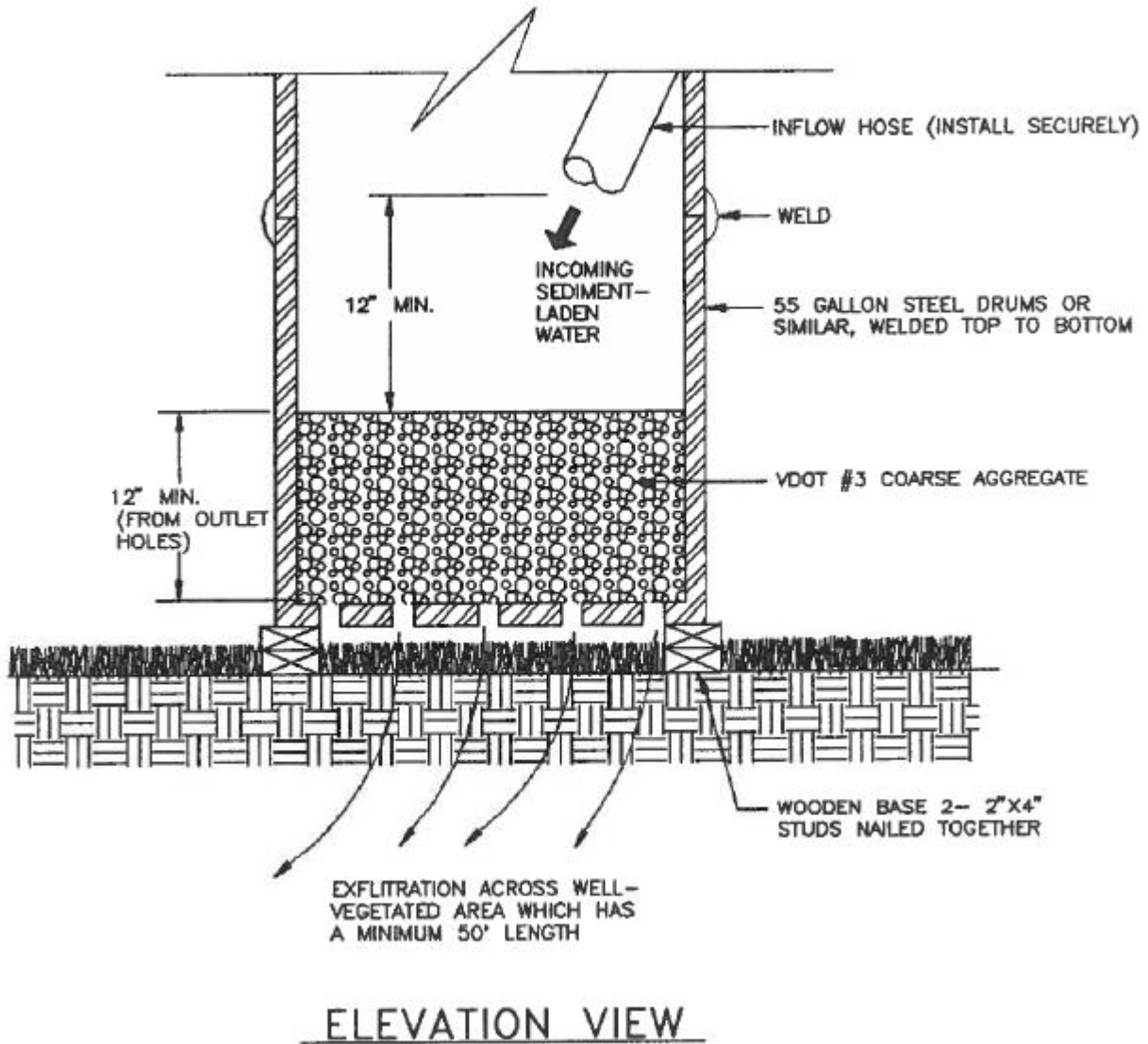

Straw Bale/Silt Fence Pit

See the Virginia Department of Environmental Quality's *Virginia Erosion and Sediment Control Handbook*, Chapter 3-3.26 for additional design specifications.

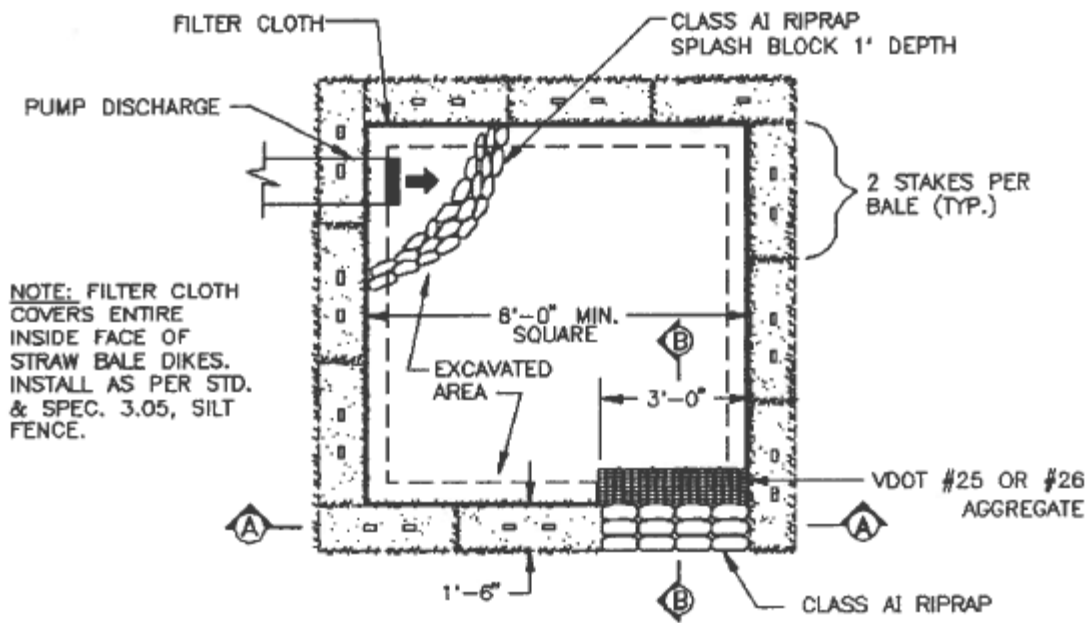

PLAN VIEW

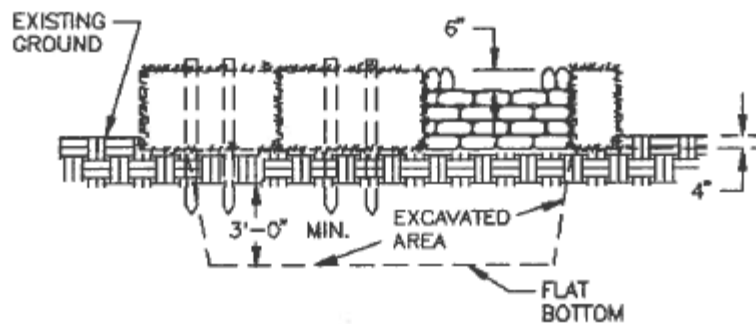

CROSS-SECTION A-A

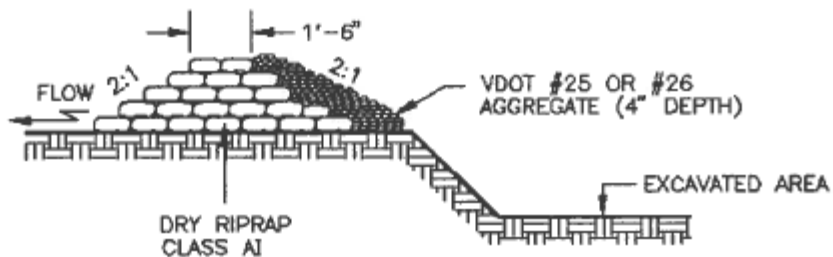

CROSS-SECTION B-B

Portable Sediment Tank

See the Virginia Department of Environmental Quality's *Virginia Erosion and Sediment Control Handbook*, Chapter 3-3.26 for additional design specifications. Storage volume of the sediment tank is determined by:

$$\text{Pump discharge (g.p.m.)} \times 16 = \text{cubic feet of storage required}$$

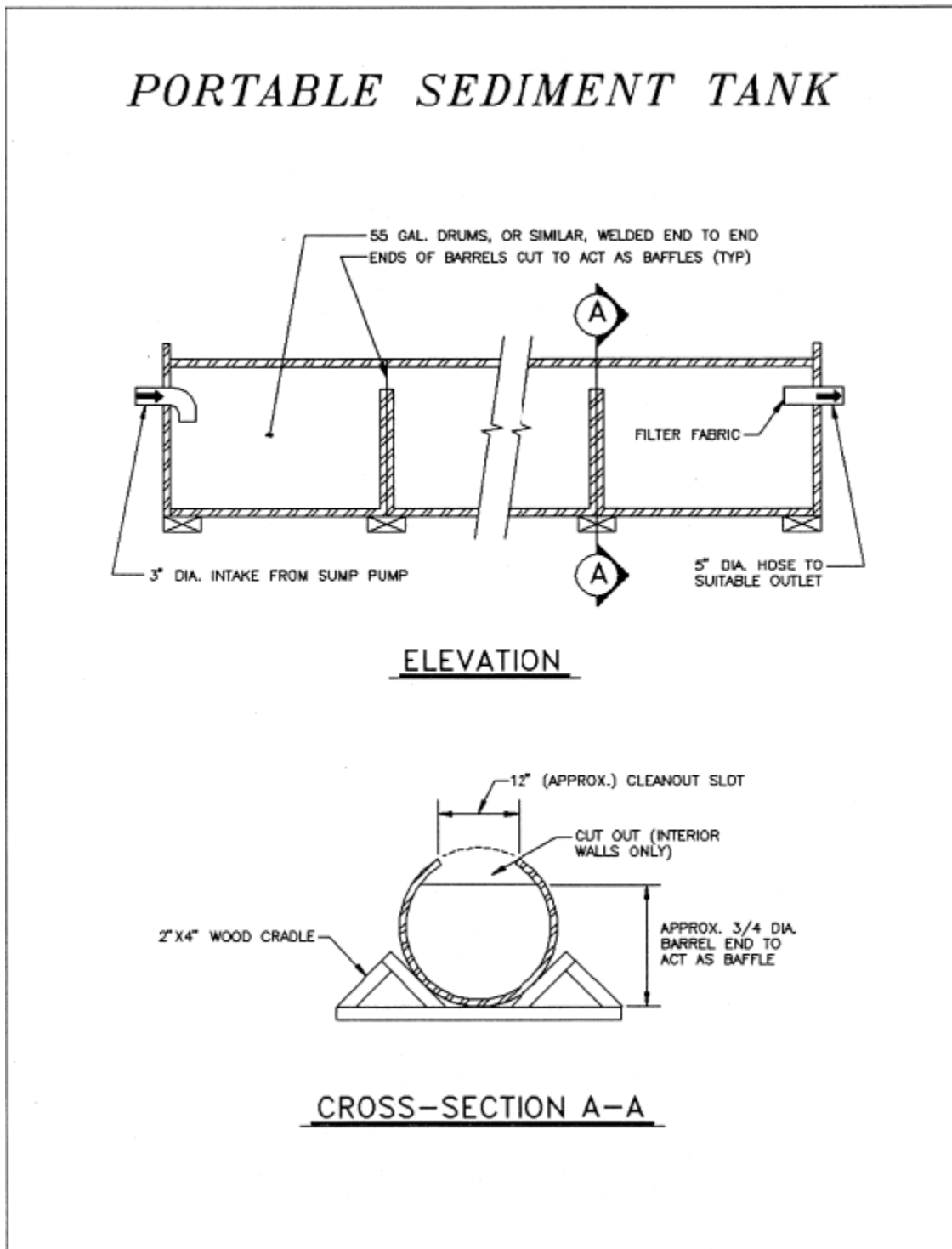

Filter Bag

The Maryland Standard F-4 for a filter bag is provided as an acceptable option for use in Arlington County if straw bales or stone are used as the layer under the filter bag. The use of mulch, leaf/wood compost, woodchips or sand is not acceptable.

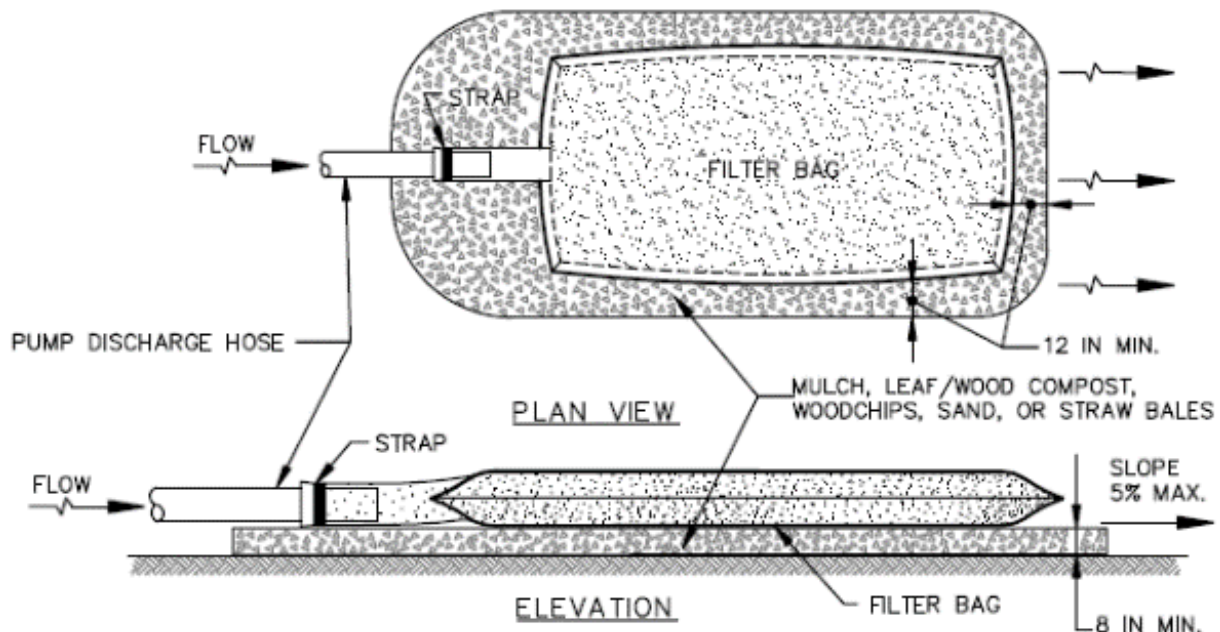

CONSTRUCTION SPECIFICATIONS

1. TIGHTLY SEAL SLEEVE AROUND THE PUMP DISCHARGE HOSE WITH A STRAP OR SIMILAR DEVICE.
2. PLACE FILTER BAG ON SUITABLE BASE (E.G., MULCH, LEAF/WOOD COMPOST, WOODCHIPS, SAND, OR STRAW BALES) LOCATED ON A LEVEL OR 5% MAXIMUM SLOPING SURFACE. DISCHARGE TO A STABILIZED AREA. EXTEND BASE A MINIMUM OF 12 INCHES FROM EDGES OF BAG.
3. CONTROL PUMPING RATE TO PREVENT EXCESSIVE PRESSURE WITHIN THE FILTER BAG IN ACCORDANCE WITH THE MANUFACTURER RECOMMENDATIONS. AS THE BAG FILLS WITH SEDIMENT, REDUCE PUMPING RATE.
4. REMOVE AND PROPERLY DISPOSE OF FILTER BAG UPON COMPLETION OF PUMPING OPERATIONS OR AFTER BAG HAS REACHED CAPACITY, WHICHEVER OCCURS FIRST. SPREAD THE DEWATERED SEDIMENT FROM THE BAG IN AN APPROVED UPLAND AREA AND STABILIZE WITH SEED AND MULCH BY THE END OF THE WORK DAY. RESTORE THE SURFACE AREA BENEATH THE BAG TO ORIGINAL CONDITION UPON REMOVAL OF THE DEVICE.
5. USE NONWOVEN GEOTEXTILE WITH DOUBLE STITCHED SEAMS USING HIGH STRENGTH THREAD. SIZE SLEEVE TO ACCOMMODATE A MAXIMUM 4 INCH DIAMETER PUMP DISCHARGE HOSE. THE BAG MUST BE MANUFACTURED FROM A NONWOVEN GEOTEXTILE THAT MEETS OR EXCEEDS MINIMUM AVERAGE ROLL VALUES (MARV) FOR THE FOLLOWING:

GRAB TENSILE	250 LB	ASTM D-4632
PUNCTURE	150 LB	ASTM D-4833
FLOW RATE	70 GAL/MIN/FT ²	ASTM D-4491
PERMITTIVITY (SEC ⁻¹)	1.2 SEC ⁻¹	ASTM D-4491
UV RESISTANCE	70% STRENGTH @ 500 HOURS	ASTM D-4355
APPARENT OPENING SIZE (AOS)	0.15-0.18 MM	ASTM D-4751
SEAM STRENGTH	90%	ASTM D-4632
6. REPLACE FILTER BAG IF BAG CLOGS OR HAS RIPS, TEARS, OR PUNCTURES. DURING OPERATION KEEP CONNECTION BETWEEN PUMP HOSE AND FILTER BAG WATER TIGHT. REPLACE BEDDING IF IT BECOMES DISPLACED.

Pump from Settling Pit

Dig a small pit and fill with fine gravel. Draw water from the top of the pit, not the bottom, with a pump to ensure that you are drawing only clear water from the pit.

Manufactured System

There are a variety of manufactured systems on the market. Choose one that fits the size constraints of your site and can adequately meet your dewatering needs.

Dewatering Practice Other

Supply a drawing and detailed description. Include information on practice maintenance.

Material Delivery and Storage

Eliminate or minimize the chances of contact with runoff and a pollution discharge event from the construction site. Designate areas of the construction site for material delivery and storage. Place near construction entrances, away from waterways, and avoid transport near drainage paths or waterways.

Best Practices

- ✓ Train employees and subcontractors on the proper material delivery and storage practices.
- ✓ Keep materials dry and protected from wind and rain. Install berms or curbs when necessary to prevent runoff.
- ✓ Before it rains, sweep and remove materials from surfaces that drain to storm drains, creeks or channels.
- ✓ Cover dry and wet materials, including exposed piles of soil and construction materials, with plastic sheeting or temporary roofs when not in use.
- ✓ Secure bags of cement after they are open. Be sure to keep wind-blown cement powder away from streets, gutters, storm drains, rainfall and runoff.
- ✓ Provide secondary containment around tanks or at a minimum berm them.
- ✓ Place a stockpile of spill cleanup materials, such as brooms, dustpans and vacuum sweepers (if desired), near the storage area where it will be readily accessible.
- ✓ Keep outdoor storage containers in good condition.



Example of a manufacturer's storage container. Note that the doors are closed and that the area surrounding the container is clean (except for some residual snow).

Chemical and Fuel Management and Storage

Best Practices

- ✓ Establish a designated fueling area where all vehicles and equipment are fueled.
- ✓ Place temporary “caps” over nearby catch basins or manhole covers so that if a spill occurs it is prevented from entering the storm drain.
- ✓ Cover fueling and chemical storage areas with an overhanging roof structure or canopy so that precipitation cannot come in contact.
- ✓ Place a stockpile of spill cleanup materials where it will be readily accessible. Include portable absorbent booms (long flexible shafts or barriers made of absorbent material) in unbermed fueling areas.
- ✓ Use DRY methods such as adsorbent materials on small spills. Remove the adsorbent materials after use promptly.
- ✓ Install protective guards around tanks and piping to prevent vehicle or forklift damage.
- ✓ Use a perimeter drain or slope pavement inward with drainage to sump. Pave area with concrete rather than asphalt.
 - Where covering is not feasible and the fuel island is surrounded by pavement, apply a suitable sealant that protects the asphalt from spilled fuels.
- ✓ Install overflow protection devices on tank systems to warn the operator to automatically shutdown transfer pumps when the tank reaches full capacity.
- ✓ Install clear tagging or labeling of all valves to reduce human error.
- ✓ Fit fuel dispensing nozzles with "hold-open latches" (automatic shutoffs) except where prohibited by local fire departments.
- ✓ Post signs at the fuel dispenser or fuel island warning vehicle owners/operators against "topping off" of vehicle fuel tanks.
- ✓ Use secondary containment when transferring fuel from the tank truck to the fuel tank.
- ✓ Regularly inspect fuel and chemical containers.
 - Check for external corrosion and structural failures such as cracks, scratches and other physical damage that may weaken the tank or container system.
 - Check for leaks or spills while pumping liquids or gases from truck to a storage facility or vice versa.
 - Check tank foundations, connections, coatings, tank walls and piping system for failures.
 - Visually inspect new tank or container installation for loose fittings, poor welding, and improper or poorly fitted gaskets.
- ✓ Integrity testing should be conducted periodically by a qualified professional.

- ✓ Report significant spills to your site inspector. Immediately call 703-558-2222 if a Hazmat team is required to address the spill.



Fuel storage example. Cans are closed and located inside of a lined, secondary containment. The cans are also covered by a plastic liner to protect them from the elements.



Chemical storage example. Containers are closed, covered by a tarp, and off of the ground.



Portable refueling mat example. The mat catches drips that may occur during the fueling process.

Material Delivery and Storage, and Chemical and Fuel management and Storage Other

Supply a drawing and detailed description. Include information on practice maintenance.

Solid Waste Disposal

Designate a waste collection area on the construction site that does not receive a substantial amount of runoff from upland areas and does not drain directly to a waterway. Ensure that containers have lids so they can be covered before periods of rain, and keep containers in a covered area whenever possible. Schedule waste collection to prevent the containers from overflowing.

Best Practices

- ✓ A sufficient number of waste containers must be kept on a site to handle the quantity of waste produced.
- ✓ Keep waste collection areas clean.
- ✓ Keep dumpster lids closed.
- ✓ Have the dumpster emptied before it becomes full and overflows its contents.
- ✓ Waste containers must be water tight.
- ✓ Check waste containers frequently for leaks and clean using DRY methods when necessary.
 - Never clean out a dumpster by power washing or hosing it out.
- ✓ Replace containers that are leaking, corroded, or otherwise deteriorating.
- ✓ Place waste containers under roofs, or cover with tarps or plastic sheeting secured around the outside of the dumpster.
- ✓ Never bury waste material. Dispose of excess dry concrete, grout and mortar in the trash.
- ✓ Create designated hazardous waste collection areas on-site.
- ✓ Place hazardous waste containers in secondary containment.
- ✓ When breaking up pavement, pick up all the pieces and dispose of them properly. Recycle large chunks of broken concrete at a landfill.



Good example of dumpster best practices. The dumpster is tarped and the tarp is secured. Traffic cones keep the area around the dumpster free of traffic and reflective tape (see bottom photo) is affixed to the ends of the dumpster.

Solid Waste Disposal Other

Supply a drawing and detailed description. Include information on practice maintenance.

Sanitary Waste

Best Practices

- ✓ Place portable toilets away from storm drains and waterways, preferably in a vegetated or pervious area. The toilet would ideally be downhill of storm drains and waterways.
- ✓ Locate portable toilets on level ground.
- ✓ Make sure portable toilets are in good working order. Check frequently for leaks.
- ✓ Regularly schedule pump outs of portable toilets.
- ✓ It is the responsibility of the construction site operator to ensure that the location and cleanliness of the portable toilet is acceptable.



*Portable toilet is located on level ground,
and is inside secondary containment.*

Sanitary Waste Other

Supply a drawing and detailed description. Include information on practice maintenance.

Equipment and Vehicle Maintenance

Use a designated area, away from storm drains, to refuel or perform vehicle or equipment maintenance.

Best Practices

- ✓ Designate one area of the site for auto parking, vehicle refueling, and routine equipment maintenance. The designated area should be away from streams or storm drain inlets.
- ✓ Storm drain inlets should be protected. See the Inlet Protection section of the Planning & Field Guide for Erosion & Sediment Control for details.
- ✓ Maintain vehicles and equipment to ensure leaks are quickly found and repaired.
- ✓ Collect all spent fluids, store in separate containers, and properly dispose as hazardous waste (recycle whenever possible).
- ✓ Make major vehicle and equipment repairs off site.
- ✓ Clean up leaks, drips and other spills immediately.
- ✓ Paved surfaces are clear of drip and spill residues, and are stain-free.
- ✓ Use DRY cleanup methods (absorbent materials, cat litter and/or rags). Sweep, shovel or vacuum up and dispose of absorbent materials.
- ✓ Remove construction equipment as soon as possible from the job site. Do not store equipment onsite.
- ✓ Cover exposed fifth wheel hitches and other oily or greasy equipment during rain events.
- ✓ Report significant spills to your site inspector. Immediately call 703-558-2222 if a Hazmat team is required to address the spill.

Equipment and Vehicle Maintenance Other

Supply a drawing and detailed description. Include information on practice maintenance.

(page intentionally left blank)